

ALLFORD
HALL
MONAGHAN
MORRIS

Horseferry House

Information
Pack



Horseferry House

Horseferry House is a refurbished speculative office building in Westminster. The redesign has created an outstanding contemporary office building centred around a dramatic atrium space animated by light and movement. The scheme was successfully pre-let and is now the headquarters of leading global fashion brand Burberry.

By enhancing the special characteristics of the existing building, the scheme has maximised and made efficient use of its latent potential. Capital costs, physical and planning constraints, value and time have all been expertly balanced without affect to the external bulk and massing of the island site.

Sector :	Offices
Location :	London, UK
Address :	255 Harrow Road London W2 5EZ
Client :	Derwent London plc
Value :	£22m
Start :	June 2005
Completion :	May 2008
Contract Type :	Design and Build JCT 1998

Key Dates

June 2005 :	Allford Hall Monaghan Morris contacted to produce initial feasibility.
October 2006 :	Planning approval with conditions granted.
January 2007 :	ISG begin main construction work on site.
May 2008 :	Practical completion achieved.
December 2008 :	Burberry take occupation of the building following category B fitout.

Areas

Gross Internal :	162,736 ft ² 15,120 m ²
------------------	---

Brief Planning History

The nature of the development was favourable with the Planning Department as the previous developer's scheme proposed to demolish the building. The planners were understandably resistant to this idea as the building has unique character and fits in well with the surrounding buildings and area. There were a number of local interest groups, including the Thorney Island Committee who were consulted on the redevelopment of Horseferry House, and whose views were sought and incorporated within the vision of the project.

Due to its location, there were a number of sensitive issues that had to be addressed in order to gain approval and planning permission. A number of studies were completed when it came to the roof terrace. These studies had to involve being able to demonstrate that any additional roof elements have minimal visual impact. The process was resolved by a mock up of elements and a site visit.

Another sensitive area was the ground floor glazing, for this a number of systems were investigated. The chosen system was half way between a curtain walling and crittall window system. The frames are of minimal thickness and are elegant in terms of profile and proportion and work with the existing buildings mullion and transom configuration. The idea of bringing clear glazing to the ground was a definite improvement for connecting the building and the street.

Project Team

Client :	Derwent London Plc
Architect :	Allford Hall Monaghan Morris
Project Manager :	Jackson Coles Construction Consultants
Quantity Surveyor :	Jackson Coles Construction Consultants
Planning Supervisor :	Jackson Coles Construction Consultants
Contract Administrator :	Jackson Coles Construction Consultants
Main contractor :	ISG Plc
Structural engineer :	Akera Engineering
Mechanical, Electrical and Public Health engineer :	Peter Deer and Associates
Lighting designer: :	Equation Lighting Design Ltd
Planning consultant:	Slaughter and May
Access consultant:	All Clear Designs Ltd
Public art consultant:	Jason Bruges Studio
Tenant:	Burberry

Allford Hall Monaghan Morris Team Members

Simon Allford, Steve Taylor, Wade Scaramucci, Glenn O' Loughlin, Matt Hayward, Susana Gonzalez, Goh Ong, Leonardo Mayol, Sandra Johnen, Luca Parmeggiani, Alexa Ratcliffe, Gareth Jones

For further information and images please contact

Allford Hall Monaghan Morris

Morelands
5-23 Old Street, London
EC1V 9HL

T: +44 (0)20 7251 5261

E: press@ahmm.co.uk

Project Description

The Horseferry Building is a redevelopment and conversion of an existing 1930's down-trodden warehouse, into an elegant, high quality new office space, with mixed-use components flanking Horseferry Road. The nine storey 'island-site' building in Westminster was designed to be attractive to potential tenants by providing a flexible and sophisticated working environment, with subdivision potential. The scheme maximises space and light to create a vibrant hub of activity and a reinvigorated street presence. The building is now the headquarters of Burberry, Britain's best-known fashion brand.

Client's Brief

The principle objective of the Client's brief was to re-develop and re-furbish the building and site to create a high quality, attractive building to provide flexible working environments and efficient use of space. A key interest was to maximise the potential of the site by balancing capital costs, physical and planning constraints, value and time.

Planning Constraints

Horseferry House is located in the local planning authority of Westminster City Council. The site falls outside of all known Conservation areas, and the existing building is not listed. The nature of the development was favourable with the planning department as the previous developer's scheme proposed to demolish the building. The planners were understandably resistant to this idea as the building has unique character and fits in well with the surrounding buildings and area. The design development process benefited from consultation with local interest groups, including the Thorney Island Committee.

A number of sensitive issues in relation to the building's location were addressed to gain approval and planning permission, particularly in relation to roof terrace. These studies had to involve being able to demonstrate that any additional roof elements have minimal visual impact.

Another sensitive area was the ground floor glazing, for this a number of systems were investigated. The chosen system was half way between a curtain walling and crittall window system. The frames are of minimal thickness and are elegant in terms of profile and proportion and work with the existing buildings mullion and transom configuration. The idea of bringing clear glazing to the ground was a definite improvement for connecting the building and the street.

Materials

These ideas of connectivity and movement are emphasized through the choice of materials. The stairs have clear screens in front of them adding to the expression of movement and the bridges contain frosted glass lens set into pre-cast concrete panels that allow refracted light and shadows to animate the space. The atrium itself is clad in white render as a cost-effective and neutral material. Finally, a cohesive design solution emphasised each entrance portal with a steel lining washed with light. The sandstone base at ground and first floor was cleaned to reveal the material's original, extraordinary colour.

Method of Construction

The existing 1930s building was steel framed with steel columns constructed within the external and lightwell walls. It had a basement, ground floor and seven upper floors. Its reinvention involved demolition works, structural alterations and a series of new structural insertions. Demolished items included the party wall between the northern and southern sections of the building, the entire central circulation core structure, all non load bearing partitions, the internal concrete staircases and lifts, all the structure within the central lightwells as well as large sections of the ground floor slab. As this demolition would have compromised the stability of the existing building, a temporary steel angle cross bracing was installed prior to the commencement of works.

A major element of the new structural work included a reinforced concrete framed circulation core constructed within the lightwell. Sections of the façade at ground and first floor level were reconfigured to create a new reception façade feature, and a new steel frame was constructed to replace the load bearing masonry wall. Large sections of the ground floor slab were rebuilt for a level access reception area and level access loading bays. Voids were cut in the ground floor slab to let light into the basement and a new steel framed structure above the new southern lightwell clad with ETFE fabric enclosed the lightwell and form an atrium.

Summary of Timetable

Allford Hall Monaghan Morris began the production of initial feasibility in June 2005, and planning approval with conditions was granted in October 2006. Main construction works began on site in January 2007, with practical completion of Allford Hall Monaghan architectural works achieved in May 2008. In December 2008 Burberry took occupation of the building following a category B fitout.

Programme and Budget constraints and opportunities

Both the programme and the budget benefited from the development's reuse of an existing building, especially when compared to previous schemes to demolish the building and rebuild. By recognising the opportunity to enclose the existing external lightwell and convert it into an atrium has greatly improved the private amenity within the building by creating a rich variety of terraces, multi use spaces and break out spaces. All occupants within the building receive access to good natural light due to the proximity of large windows and two atria.

Conclusion

Horseferry House has reinvented a tired but elegant London city building into a lively office headquarters for a highly sophisticated client. The redesign has created an outstanding contemporary speculative office building centred around a dramatic atrium space animated by light and movement.

Existing Site



Aerial Image highlighting the site location



View of building from Horseferry Road looking west

Planning History



Views for planning approval

Design Development

The principle objective of the Client's brief was to re-develop and re-furbish the building and site to create a high quality, attractive building to provide flexible working environments and efficient use of space. A key interest was to maximise the potential of the site by balancing capital costs, physical and planning constraints, value and time. Design Development was focused on the following key areas.

Key Areas

- Planning History
- Engaging with the Street
- Making New Entrances
- The Atrium
- Bridges
- The Lightwell
- Typical Office
- Ground Floor and Lower Ground Office
- The ETFE Roof
- The Pop Out
- Roof Terraces



Design Development Model

Design Development

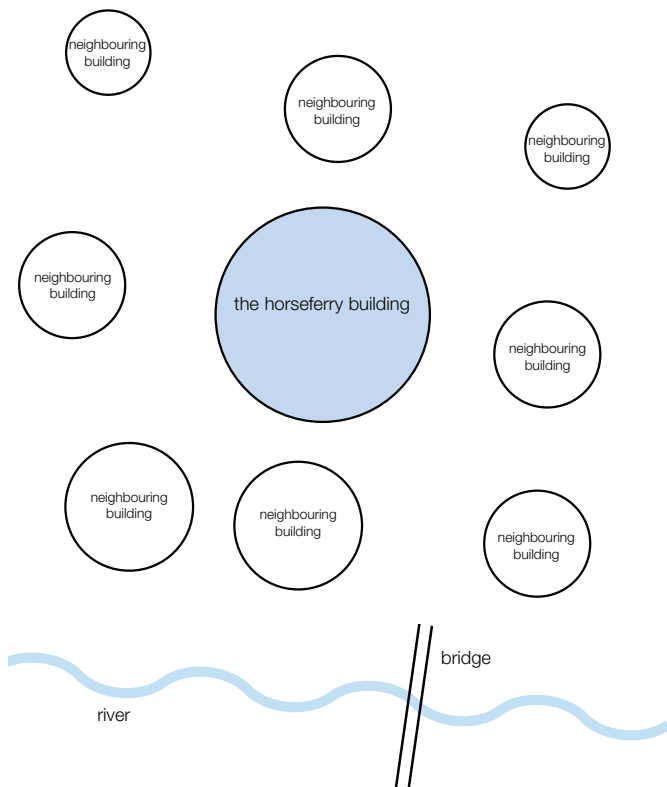

The building as an island or complete city block

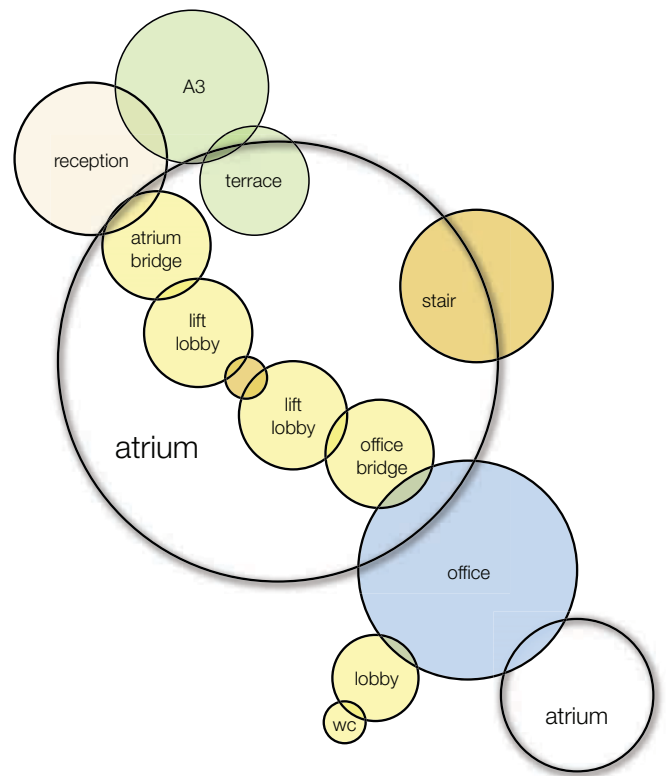

The atrium as space of connection

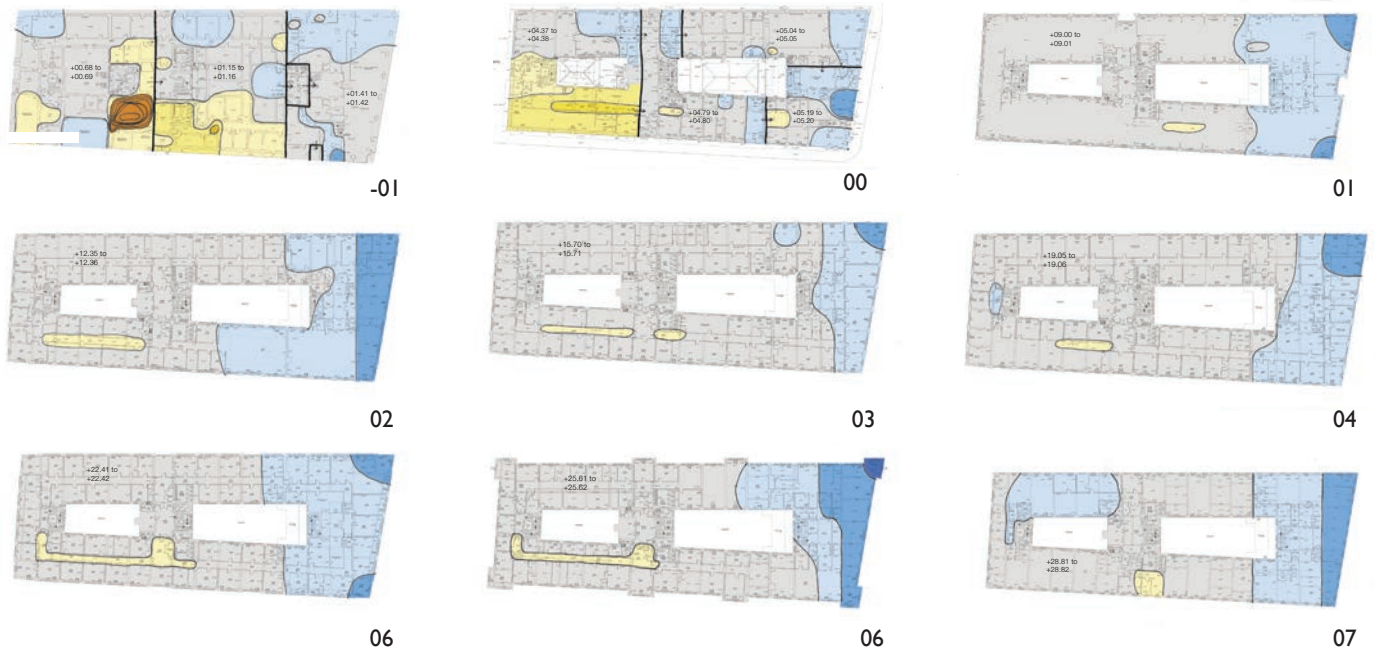

The difficulty of working with an existing building - a contour map showing variance in existing floor levels - typically 100mm

Engaging with the Street



CGI of the Building from Horseferry Road looking South East towards the main entrance



Illustration from Horseferry Road looking South East towards main entrance



Views of the existing building showing entrance to Horseferry Road

Making New Entrances



Illustration and existing view of Horseferry entrance

Illustration and existing view of Page Street fire escape

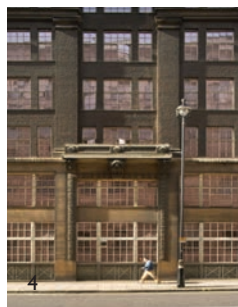

Illustration and existing view of Thorney Street entrance

Illustration and existing view of Thorney Street

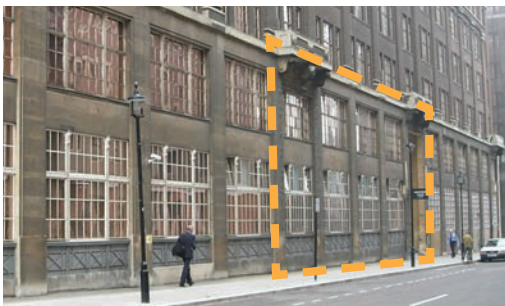
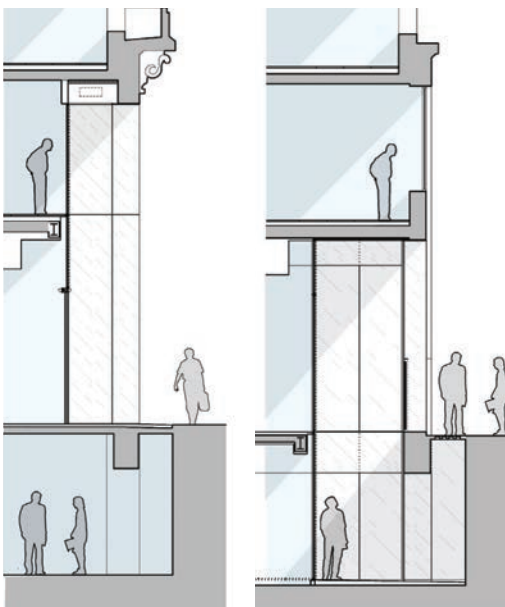

Illustration with existing photo marking the new main entrance on Dean Ryle Street



Sections through the entrances showing double portals

Completed building - new double portal entrances

The Atrium and Bridges



CGI of atrium



Existing views of atrium



Diagram showing the relocation of the stairs and core in the central atrium to create two atria - a covered public atrium and an open private lightwell

The Atrium and Bridges



Illustration of atrium from ground floor lift lobby

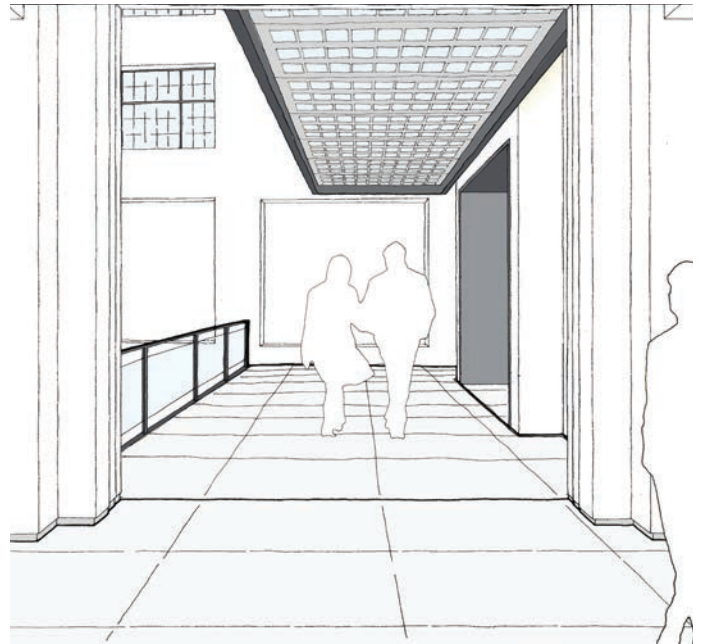

Illustration of bridge to ground floor lift lobby from reception



Views of model of atrium



The Atrium and Bridges, completed building



Bridges in use

The Atrium and Bridges

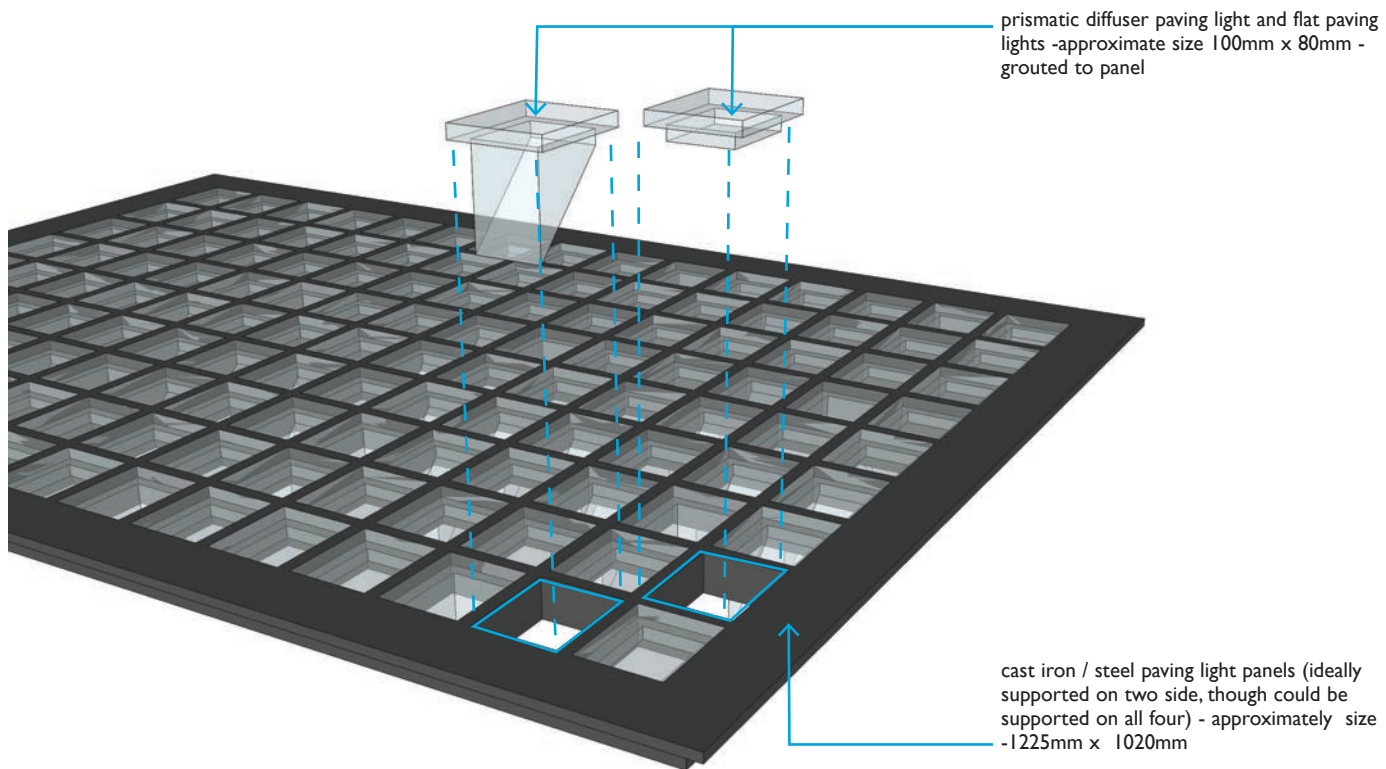

CGI of the bridge with extruded examples of the glass blocks that will be embedded into the Concrete surface.



New metal bridges linking office space across Atrium (7 bridges in North Atrium, 7 bridges in South Atrium)

steel/ glass balustrade design 'L' angle supporting edge of paving light panel

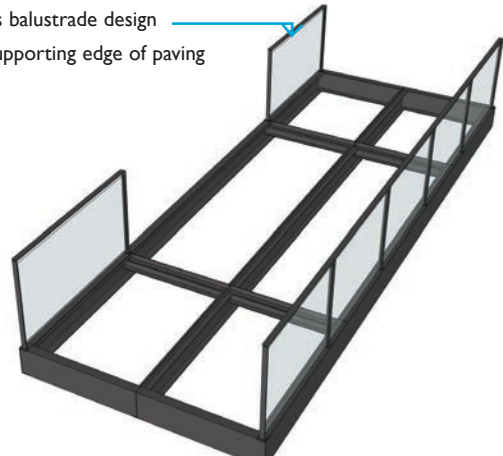

cast iron / steel paving light panels

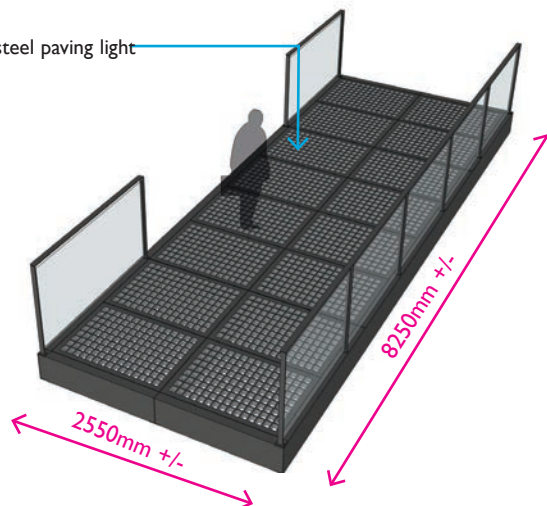

The Lightwell

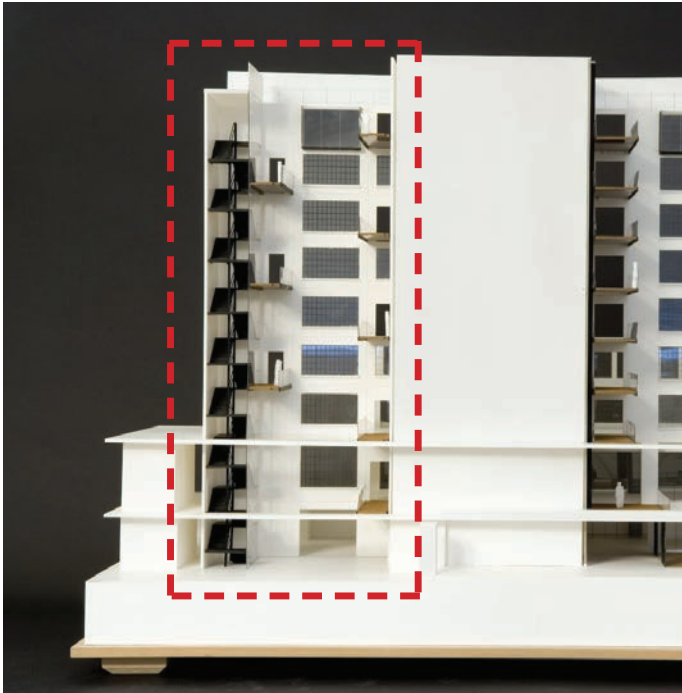

View of model of lightwell



Sketch of lightwell



Illustrations of lightwell

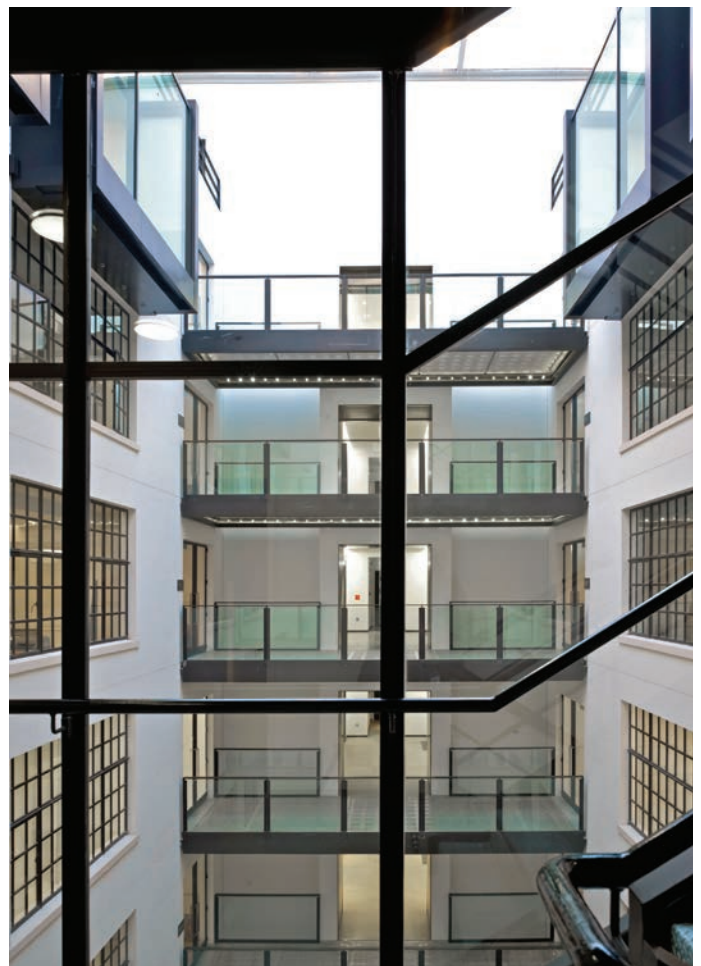
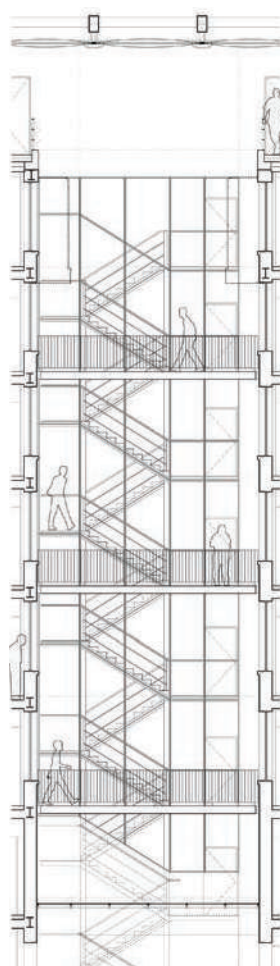

Lightwell, near completion

Typical Office

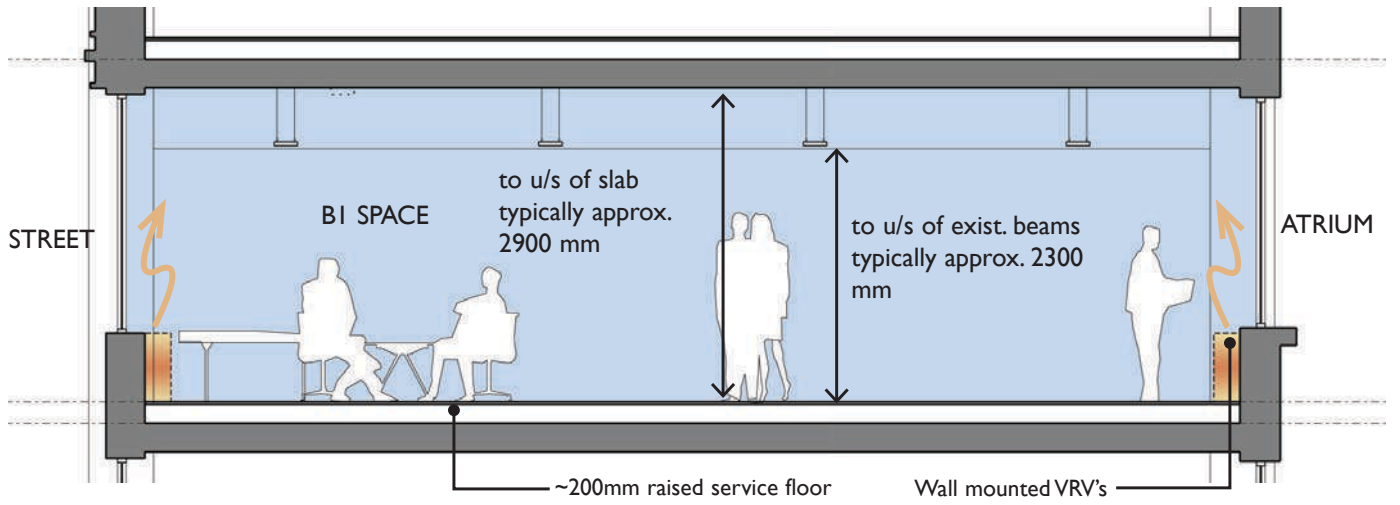

Typical office floor: Section (Level 4) NTS



View of existing office floor



Illustration of typical office



View of mock up



View of finished floor plate



View into offices, from bridge



Ground Floor and Lower Ground Office



CGI of lightwell



CGI of ground and lower ground office



View of ground and lower ground office, finished project

The ETFE Roof

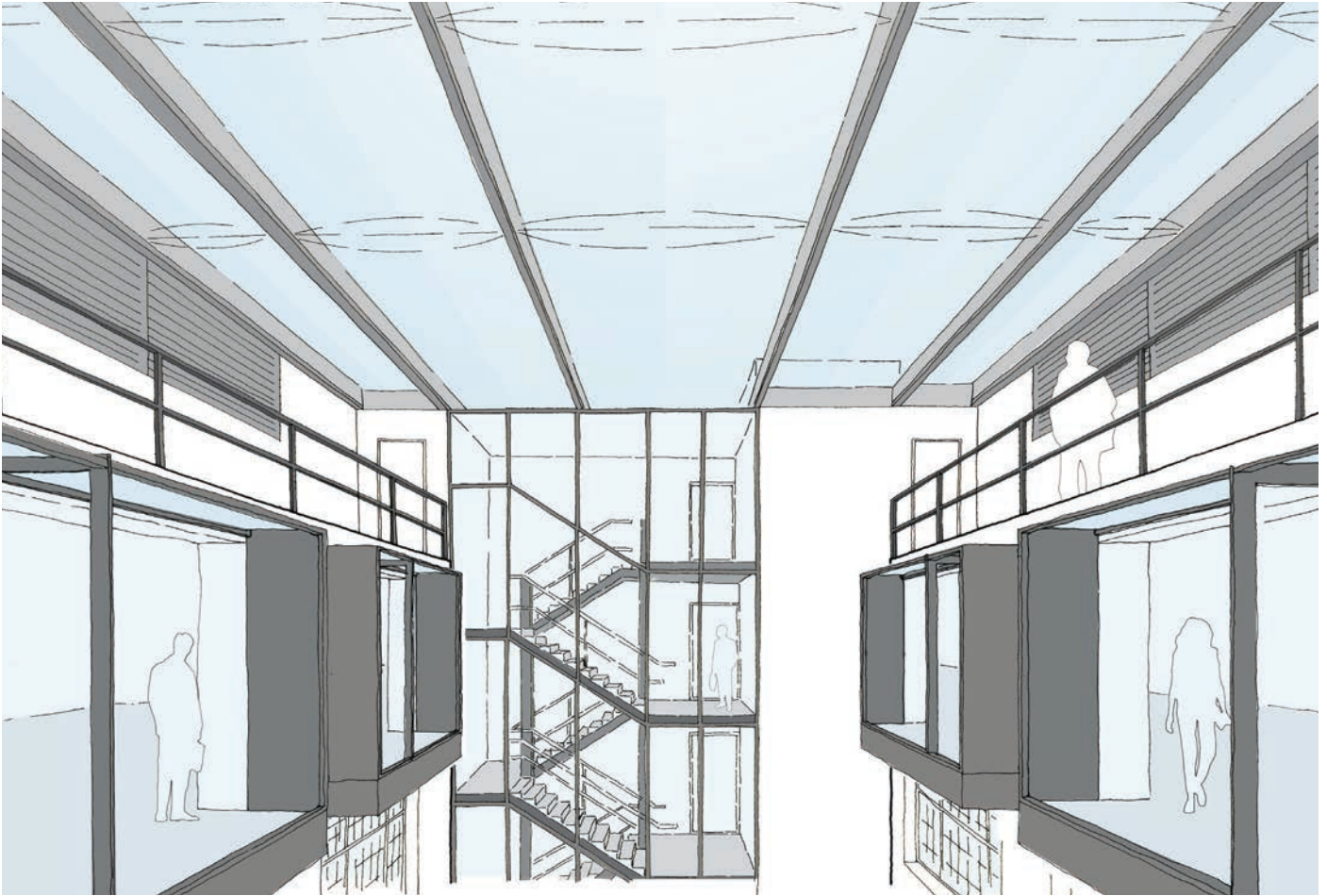

Illustration of pop ups and ETFE roof from seventh floor office bridge



ETFE roof during construction



ETFE roof, completed building

The Pop Outs



View of seventh floor pop outs

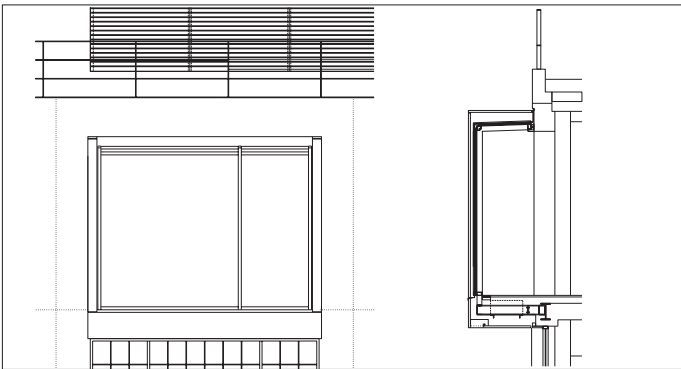

Drawing of pop outs



Illustration of view of pop outs from the inside



View of one of the higher level pop outs, completed building

The Pop Ups



Illustration of pop ups to terrace from seventh floor office

Roof Terraces



Illustration of north terrace



Sketch of terrace

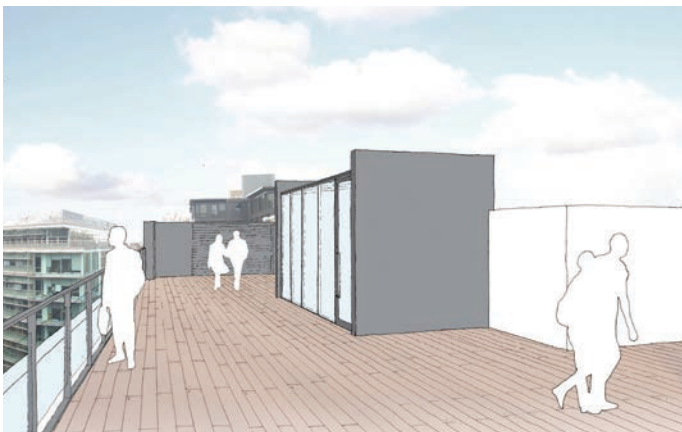

Illustration of south terrace

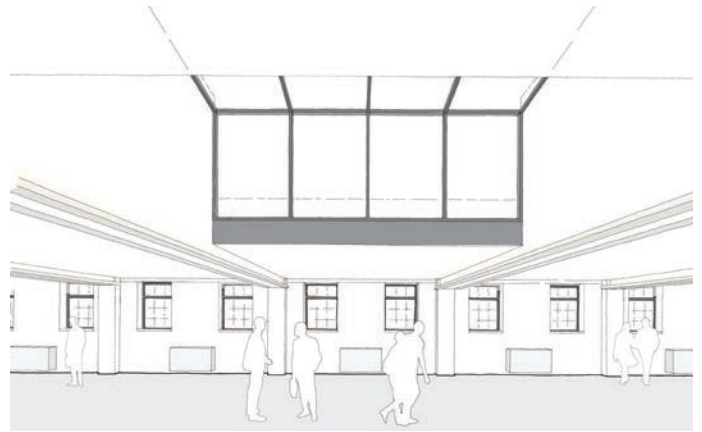
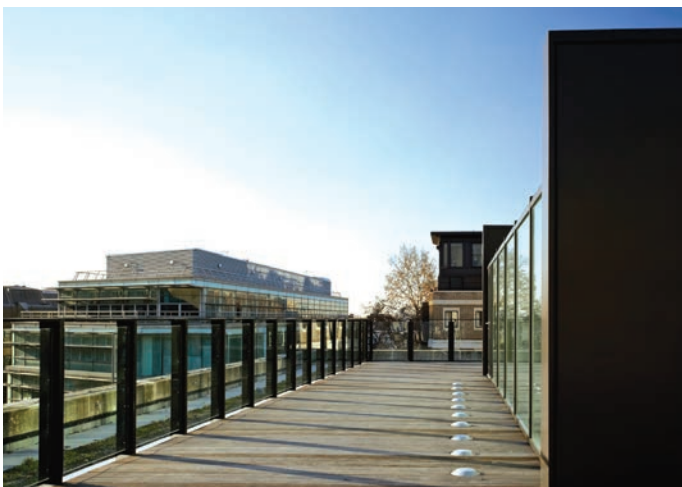
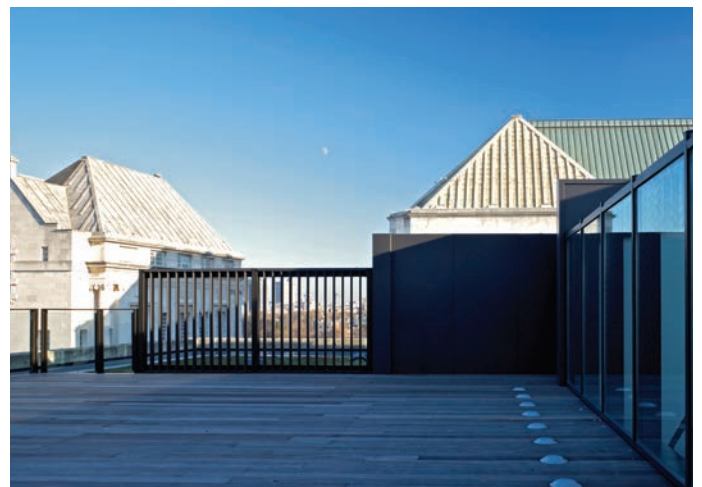

Illustration of pop ups to provide light to seventh floor office



South terrace, finished project



Terrace, finished project

Structure

The following are the structural alterations to the existing building.

Demolition

Areas of the building that were demolished included:

- The party wall between the northern and southern sections of the building.
- The entire central circulation core structure (stairs/lifts and surrounding structure)
- All the non load bearing partitions in the building.
- The internal concrete staircases.
- The internal lifts.
- All the structure within the central lightwells (including the fire escape staircases).
- Large sections of the ground floor slab.
- Removal of all the ground floor strengthening beams.

In order to maintain the building stability, temporary steel angle cross bracing was installed prior to the commencement of demolition works.

Proposed new Structure

The following are the main areas of new structural work:

- A new reinforced concrete framed circulation core (lifts/ stairs) was constructed within the lightwell.
- Two new steel framed fire escape staircases was constructed at the northern and southern ends of the lightwell.
- A new steel frame was constructed to replace the load bearing masonry wall.
- Slab infills was placed where the existing lifts and stairs were demolished.
- Large sections of the ground floor slab were rebuilt at street level for a level access reception area and level access loading bays.
- Sections of the façade at ground and first floor level were reconfigured to create a new reception façade feature.
- Voids were cut in the ground floor slab to let light into the basement.
- All the new structure within the lightwell had piled foundations.
- A new steel framed structure above the new southern lightwell clad with ETFE fabric enclosed the lightwell and form an atrium.

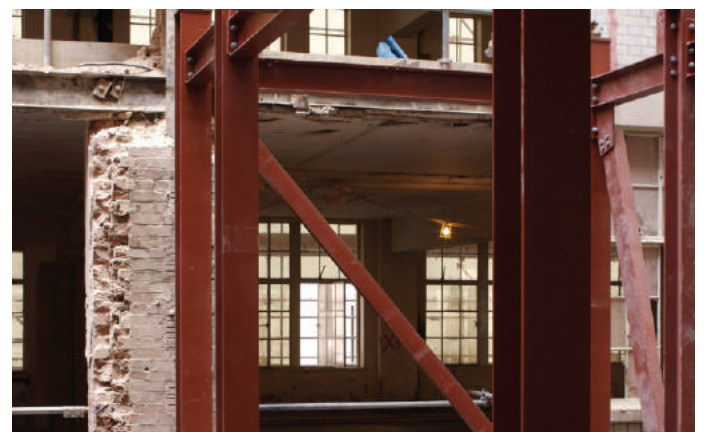
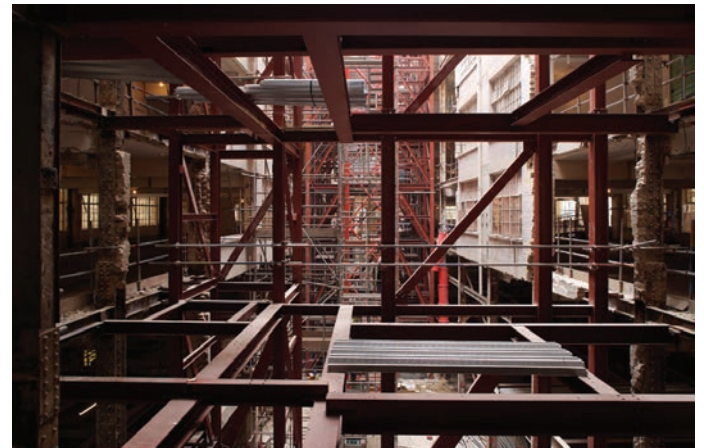

Construction views of steel work installation

Sustainability

Horseferry House's utilises a VRV system which was considered to be the most economic and efficient in terms of energy consumption and area loss. A displacement strategy was originally investigated but discounted due to the low floor to soffit heights. The VRV system also allows for local variations and therefore gives choice to the users.

Localised control over temperature control was further improved by installing operable windows which replace air conditioning for many month of the year. These new windows were double glazed and offered significant thermal improvement over the existing single glazed windows.

In order to improve the building's existing thermal performance and therefore reduce its operational energy consumption, all the walls were re-lined with insulation and plasterboard. Thermal performance was thus enhanced.

The development does not provide any car parking spaces as there are excellent public transport links in the area. The building provides 92 bike spaces, showers and locker rooms.

Due to the nature of the development's reuse of an existing building, the project is inherently sustainable especially when compared to previous schemes to demolish the building and rebuild. Demolition and construction waste was processed separately and good dedicated recycling facilities have been provided for the building's operation.

The development provides public art as a means to include the wider community.

Private amenity within the building is included in the form of terraces, multi use spaces and break out spaces. All occupants within the building receive access to good natural light due to the proximity of large windows and two atria. The top floor is especially well lit due it its proximity to the top of the atria as well as the pop ups which supplement the natural light. The users also benefit from low VOC finishes.

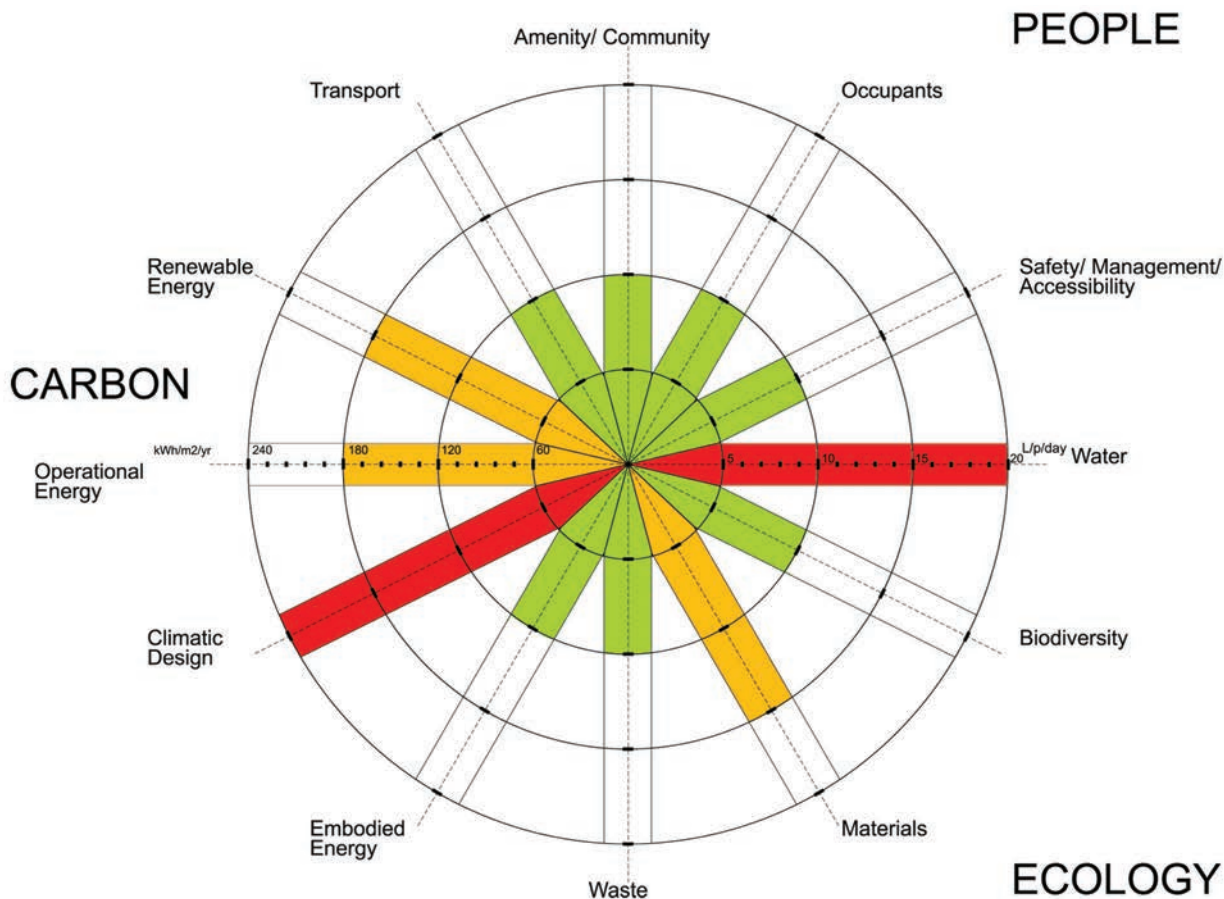

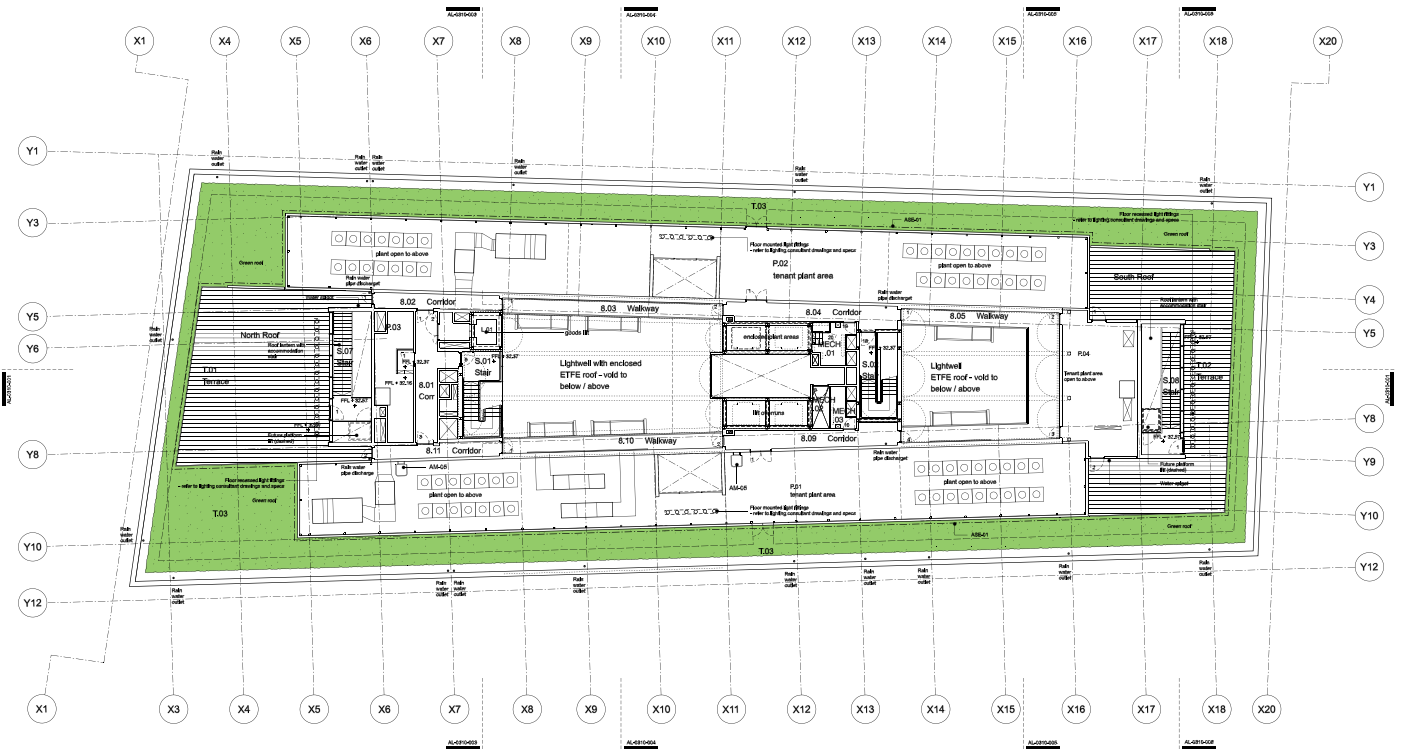

Roof plan showing extent of green roof

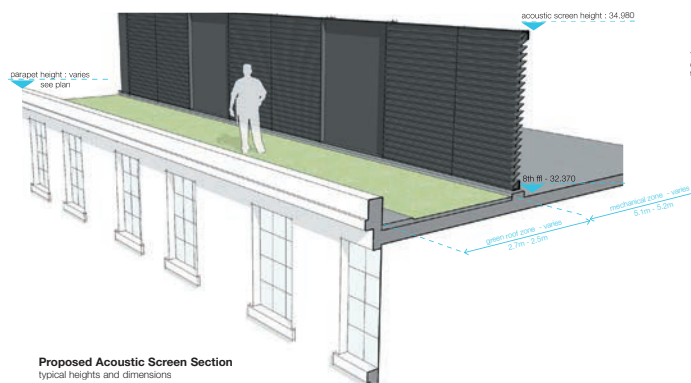

Proposed Acoustic Screen Section
typical heights and dimensions

Acoustic screen to VRV condensers

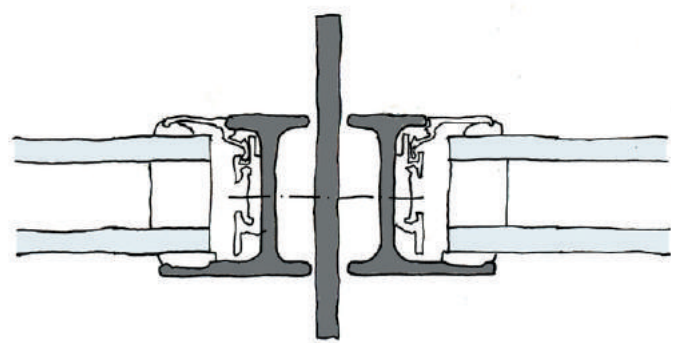

Plan detail of ground floor glazed facade

Drawings

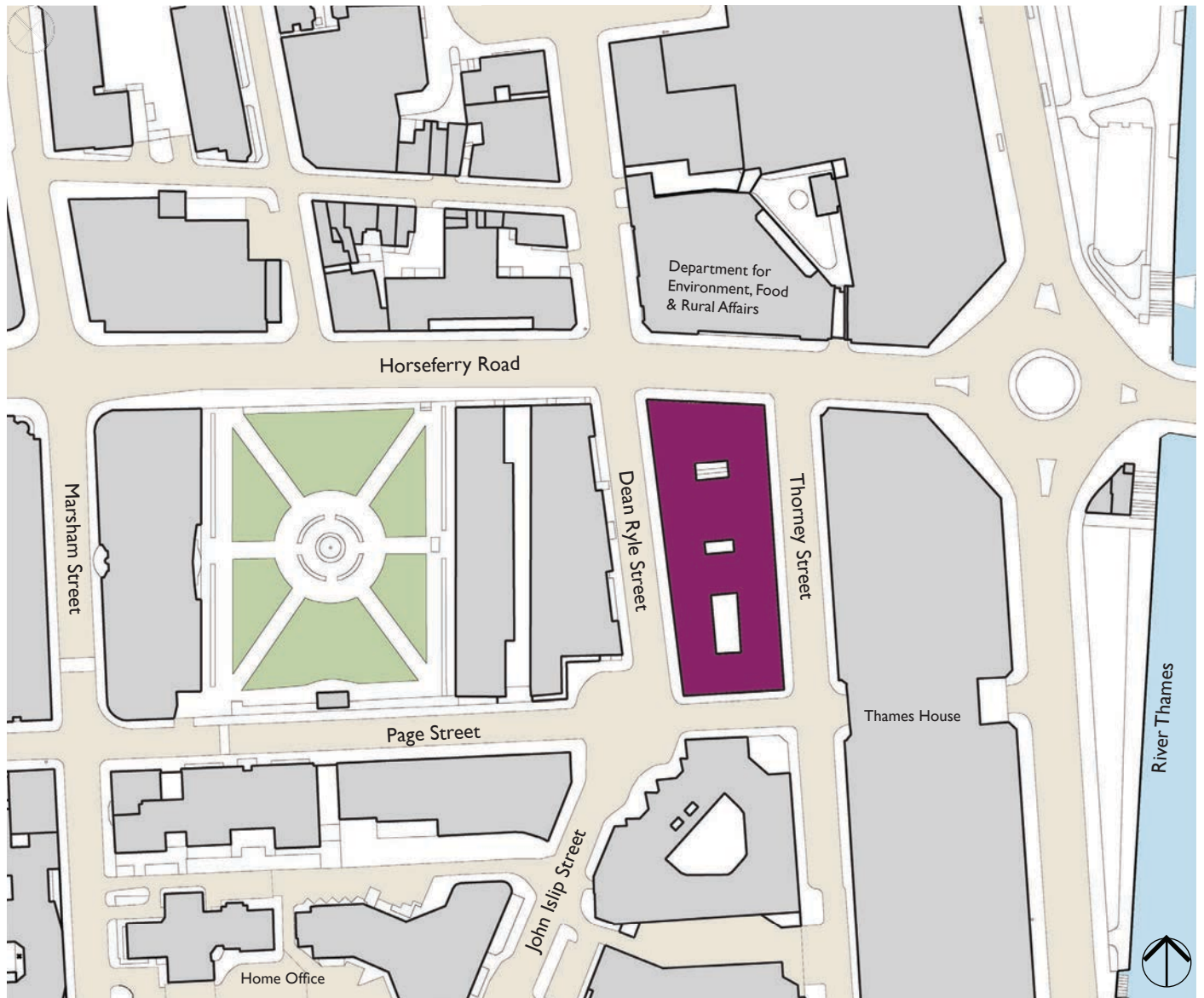

Location Plan

0m 10 20 50

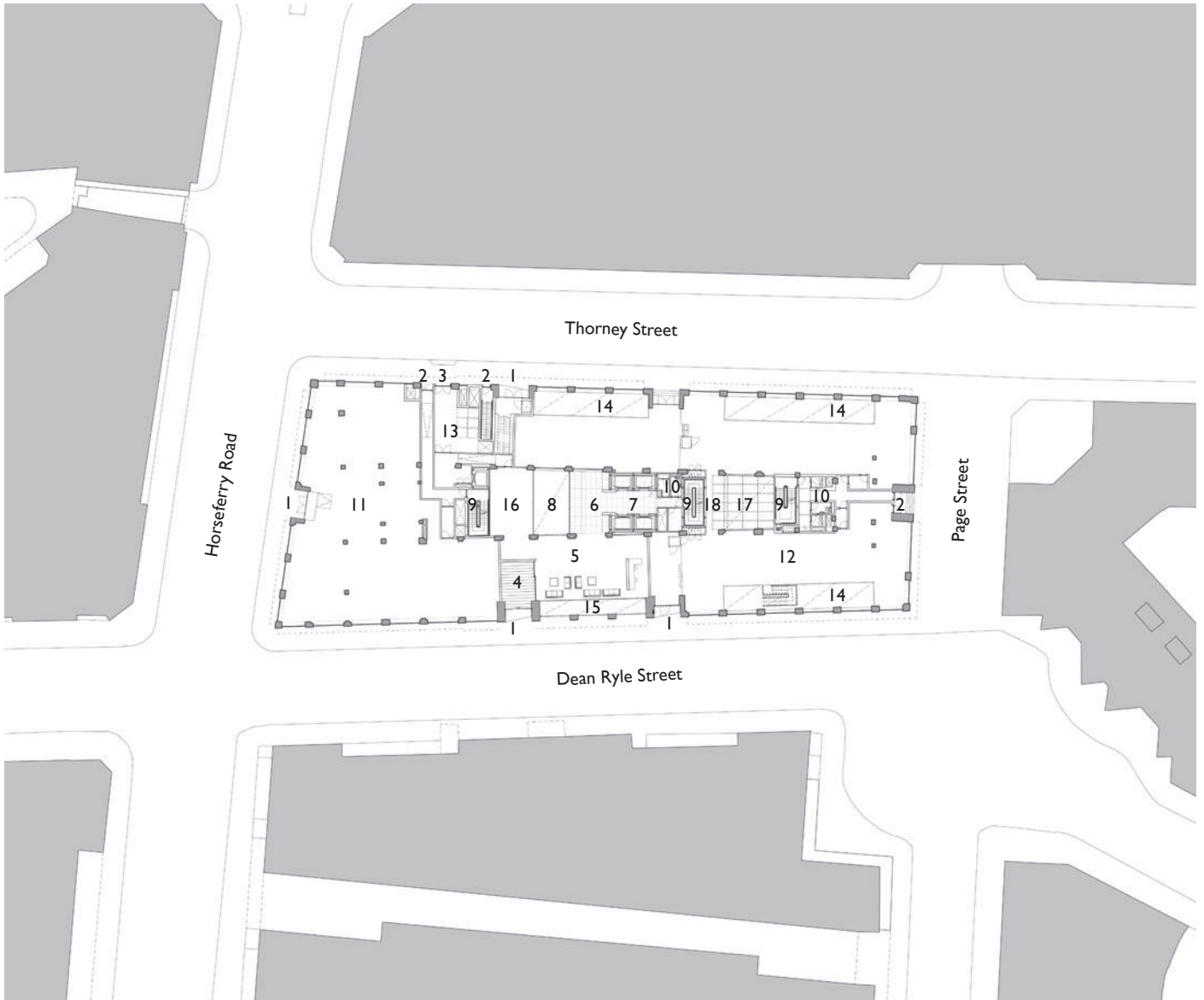

Ground Floor Plan

KEY

- 1 Entrances
- 2 Fire escapes
- 3 Loading bay entrance
- 4 Entrance vestibule
- 5 Reception
- 6 Bridge
- 7 Lift lobby
- 8 Void to court below
- 9 Escape stairs
- 10 WCs
- 11 Multi use space
- 12 Office space
- 13 Back of house
- 14 Voids to lower ground floor space
- 15 Void to lower ground terrace
- 16 Break out space at base of atrium
- 17 Rooflight
- 18 Bridge

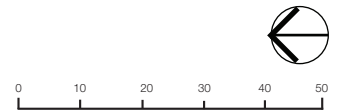

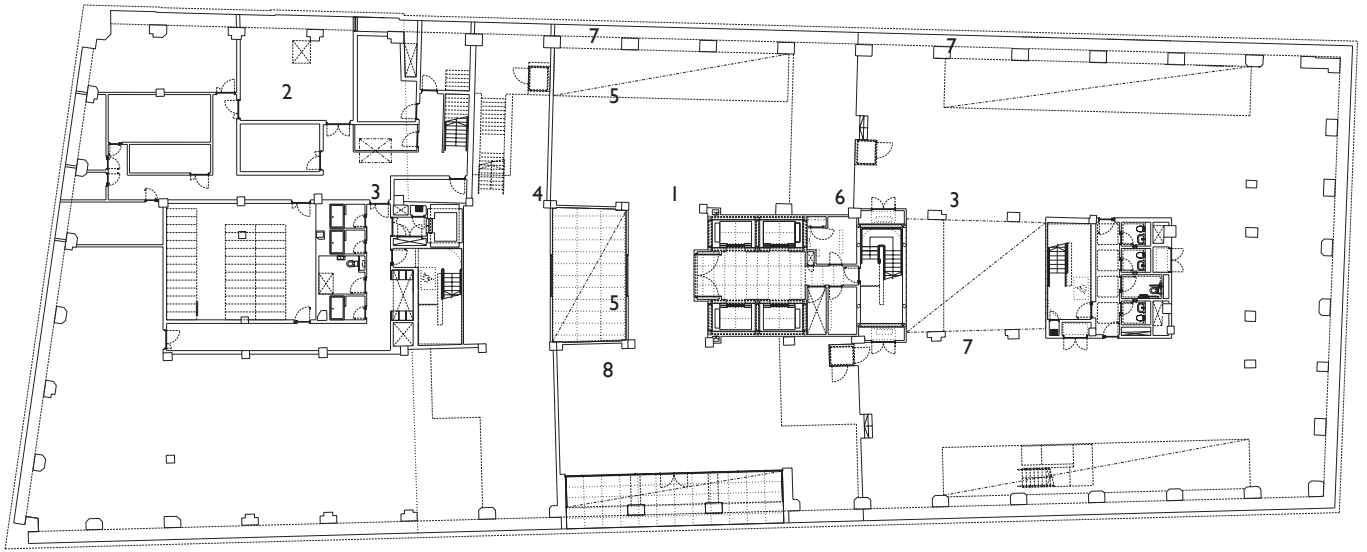

Lower Ground Floor Plan

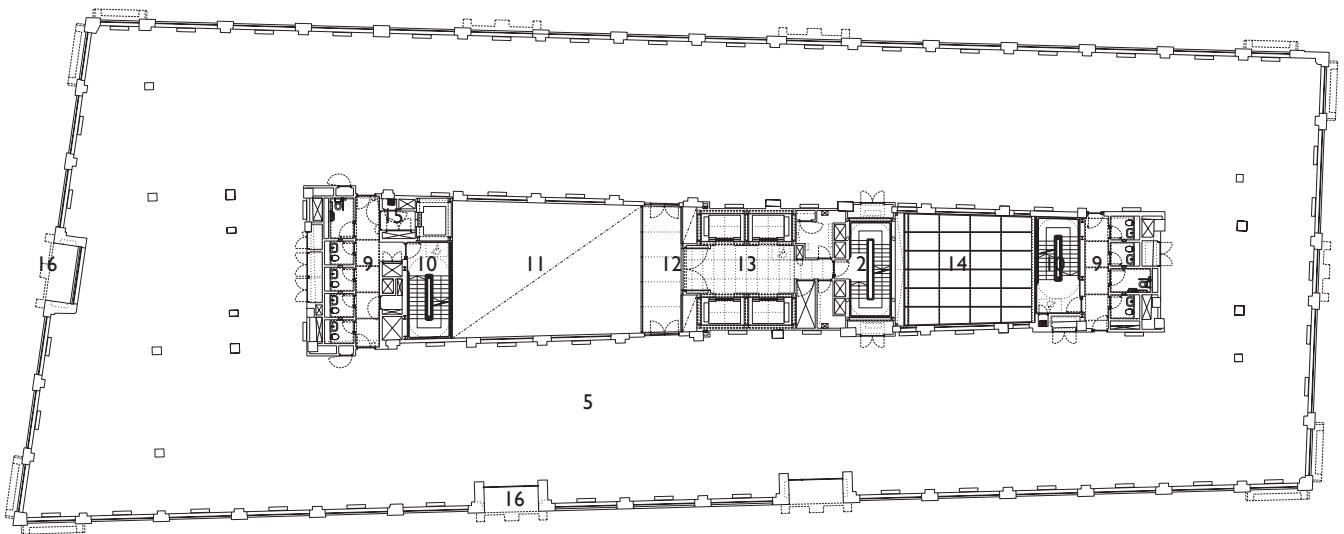

First Floor Plan

KEY

- | | |
|---------------------------|---------------------------------|
| 1 Multi-use space | 9 WC |
| 2 Back of house | 10 Escape stair |
| 3 WC & shower block | 11 Void to atrium |
| 4 Open court to atrium | 12 Bridge |
| 5 Office space | 13 Lift lobby |
| 6 Void to lightwell above | 14 Rooflight to lightwell above |
| 7 Void to office above | 15 Goods lift |
| 8 Open terrace | 16 Double height entrance void |



0m 5 10

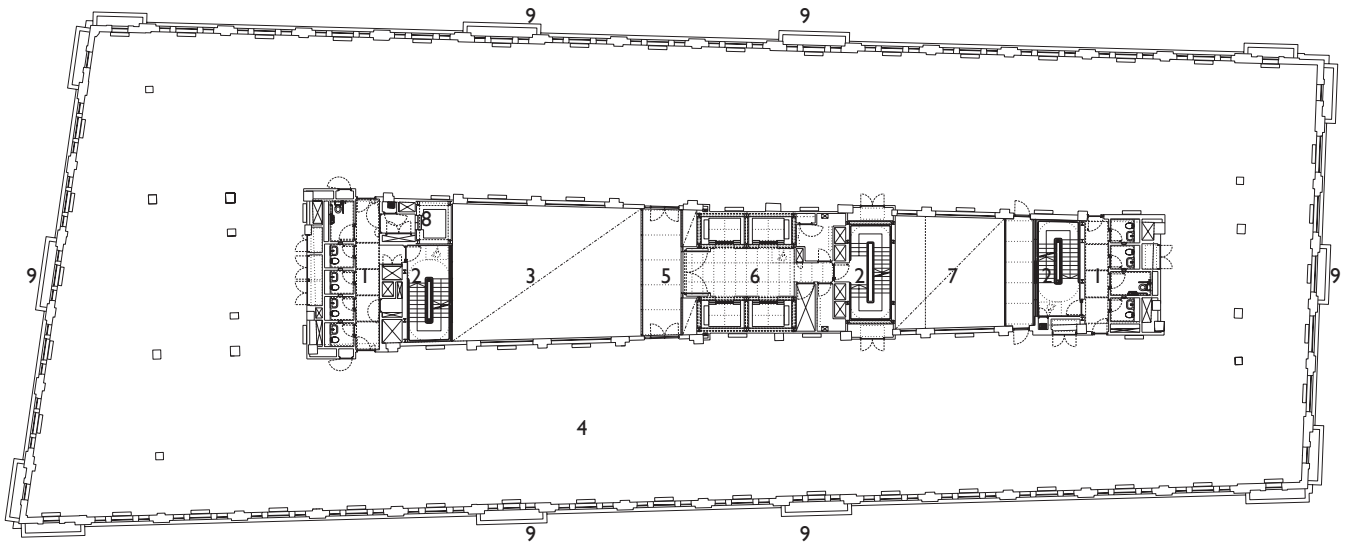

Second floor plan

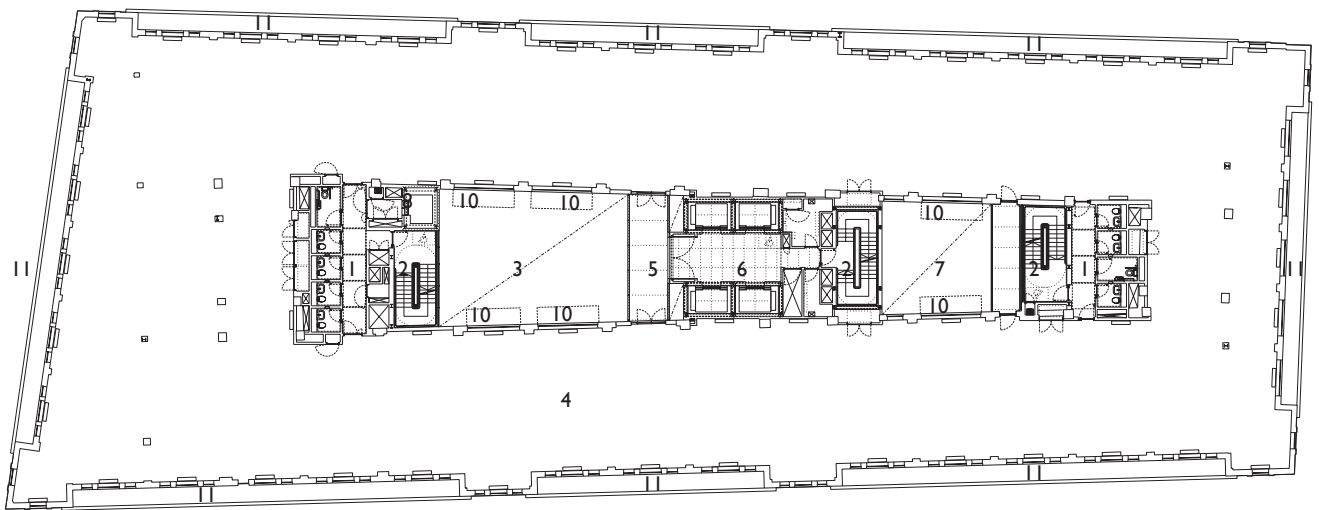

Sixth floor plan

KEY

- | | |
|--------------------------------|----------------------|
| 1 WC | 9 Top of portals |
| 2 Escape stair | 10 Pop Outs above |
| 3 Void to atrium | 11 Setback in facade |
| 4 Office space | |
| 5 Bridge | |
| 6 Lift lobby | |
| 7 Rooflight to lightwell above | |
| 8 Goods lift | |

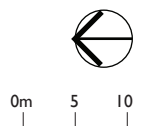



Section through Atrium and Lightwell West



KEY

- 1 Office space
- 2 Entry bridges
- 3 Escape stair
- 4 Atrium
- 5 Lightwell
- 6 ETFE roof
- 7 Plant
- 8 Pop ups
- 9 WCs
- 10 Rooflight
- 11 Entry portal
- 12 Fire escape
- 13 Multi use space
- 14 Court at base of atrium
- 15 Break out space
- 16 Opening to receptions
- 17 Pop outs
- 18 Terraces
- 19 Opening to office
- 20 Louvres to plant
- 21 Lift lobby

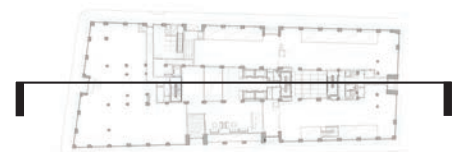

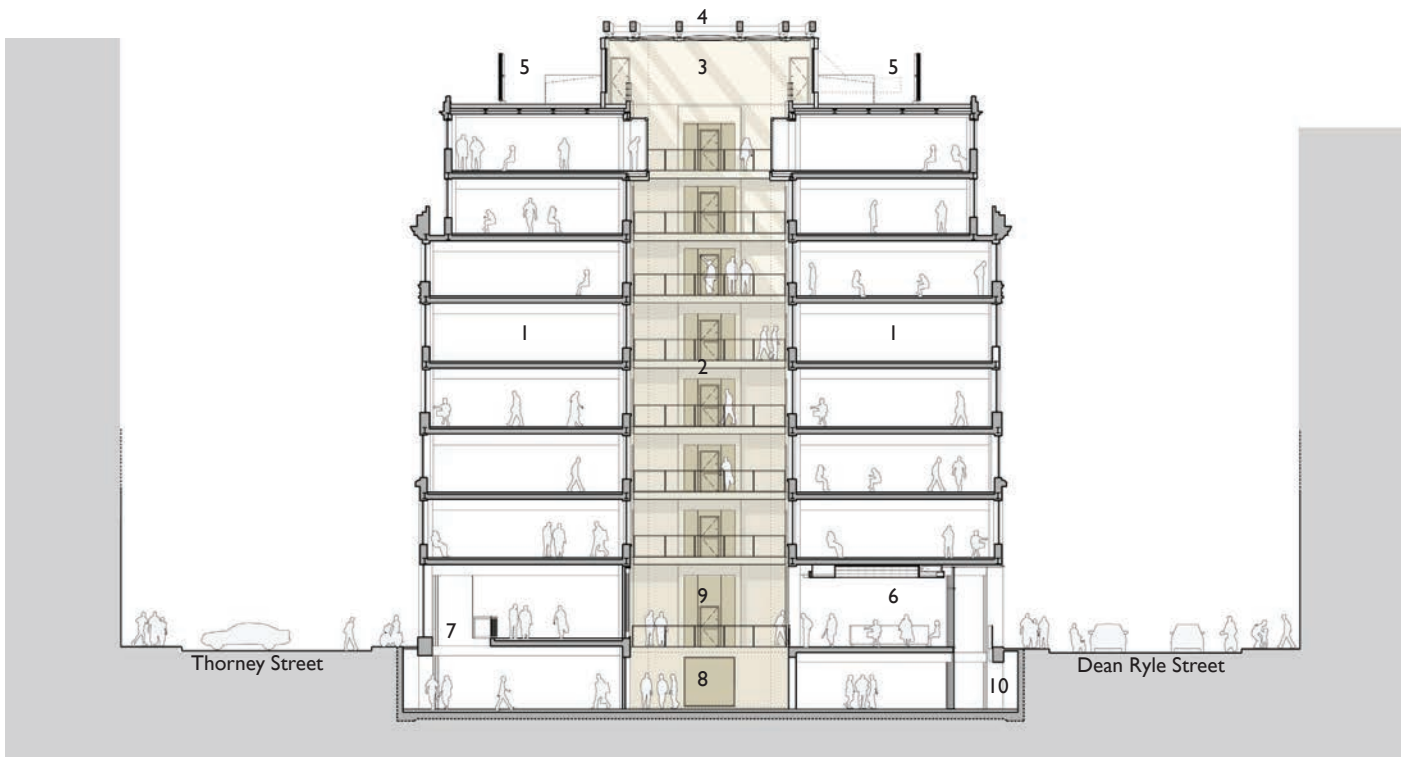

Section through Atrium Looking South

0m 5m 10m

KEY

- | | | | | |
|----------------|-------------|-------------|---------------------------|--------------|
| 1 Office space | 3 Atrium | 5 Plant | 7 Void | 9 Lift lobby |
| 2 Entry bridge | 4 ETFE roof | 6 Reception | 8 Court at base of atrium | 10 Terrace |

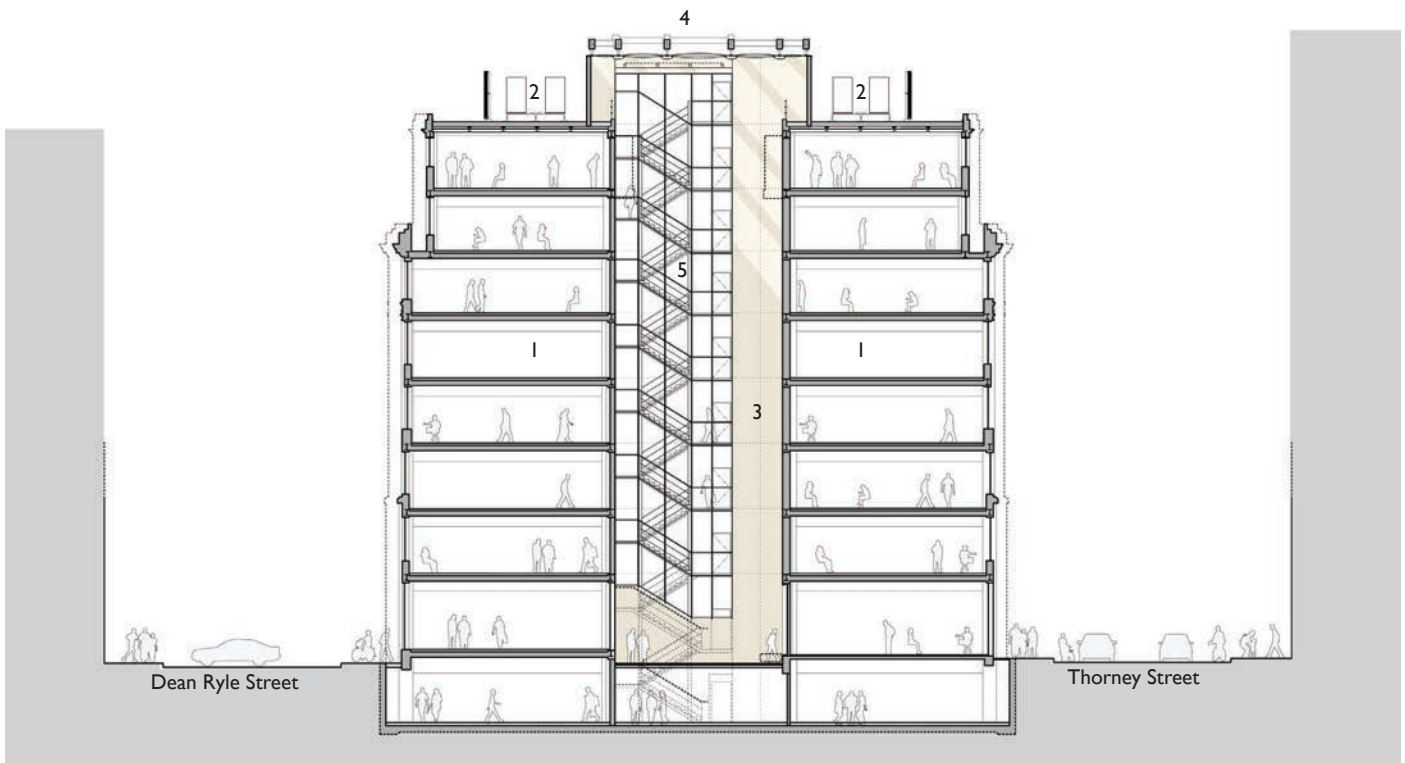

Section through Atrium Looking North

0m 5m 10m

KEY

- | | | |
|----------------|-------------|----------------|
| 1 Office space | 3 Atrium | 5 Escape stair |
| 2 Plant | 4 ETFE Roof | |



Dean Ryle Street Elevation

0m 5m 10m

KEY

- | | |
|---------------------------------------|---------------------------------------|
| 1 Ground floor facade | 4 Balustrade to seventh floor terrace |
| 2 Entrance portal | 5 Acoustic roof screen |
| 3 Balustrade to void to terrace below | 6 ETFE roof |



Thorney Street Elevation

0m 5m 10m

KEY

- | | |
|-----------------------|-------------------------|
| 1 Ground floor facade | 5 Acoustic plant screen |
| 2 Entrance portal | 6 ETFE roof |
| 3 Loading bay | 7 Crittall windows |
| 4 Fire escape | |

Final Photos



View from Dean Ryle Street looking north

A645_N164 © Timothy Soar



View of the portal on Page Street



View looking south of the Dean Ryle street facade



View of the double height entrance on Dean Ryle Street



Restored view of sandstone detail around the buildings portals



View of the reception and the underside of the pre-cast concrete bridges



View of the reception from the draft lobby

A645_475 © Timothy Soar

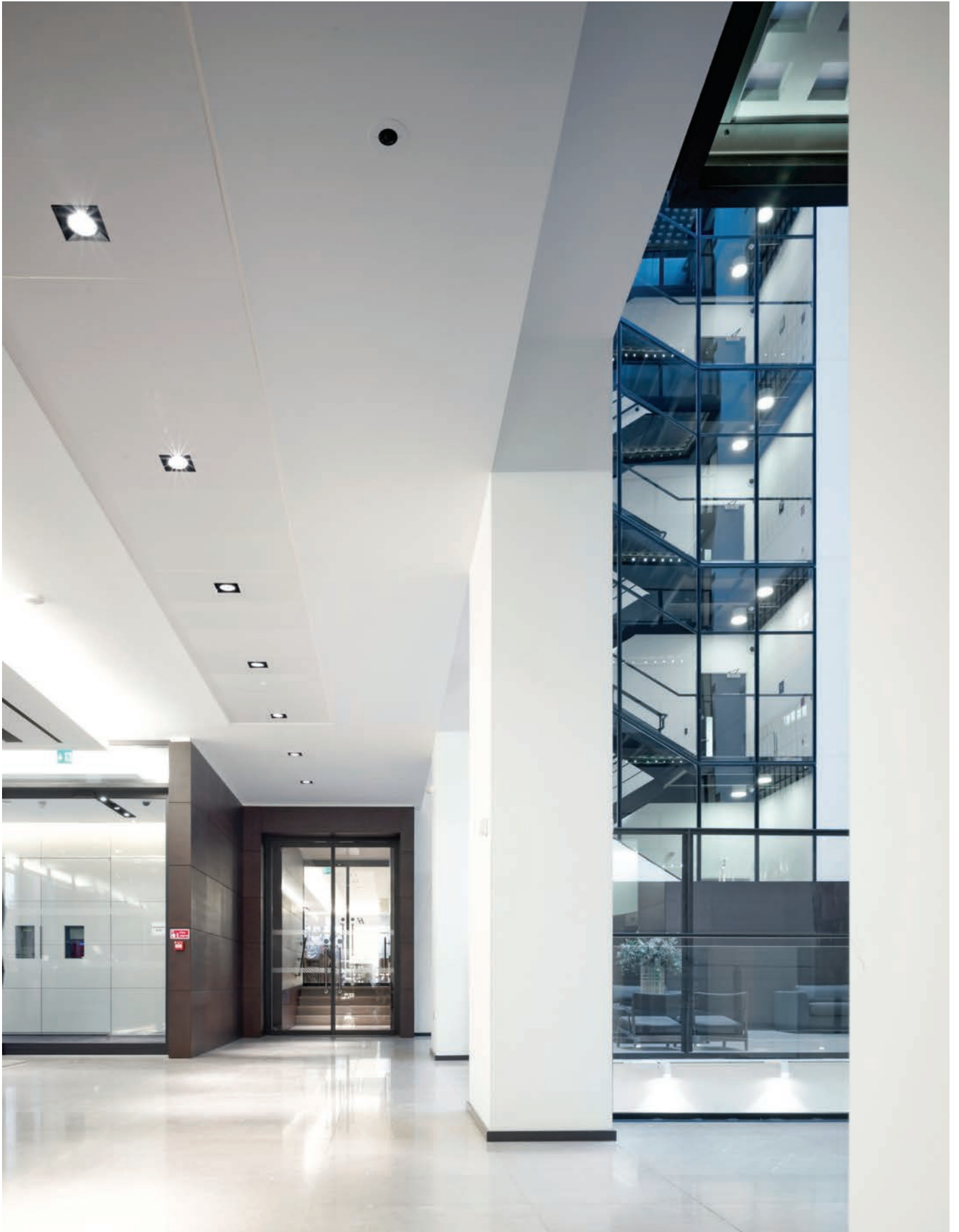

View from the reception of the draught lobby and the multi-use space entrance



View of the ground floor lift lobby through the metal portals



View across atrium of the pre-cast bridges in front of the central core



View across the atrium at the sculpture court and waiting area on ground level



View from across the atrium towards the reception and the pre-cast concrete bridges



View of the atrium and the ETFE roof

A645_460 © Timothy Soar



View from a bridge towards the seventh floor atrium pop outs



View from a typical lift lobby towards the bridge and the atrium



View of pre-cast concrete bridges in front of the central core



View across the atrium towards the entrance and the escape stairs



View from escape stairs with glazed screen in front

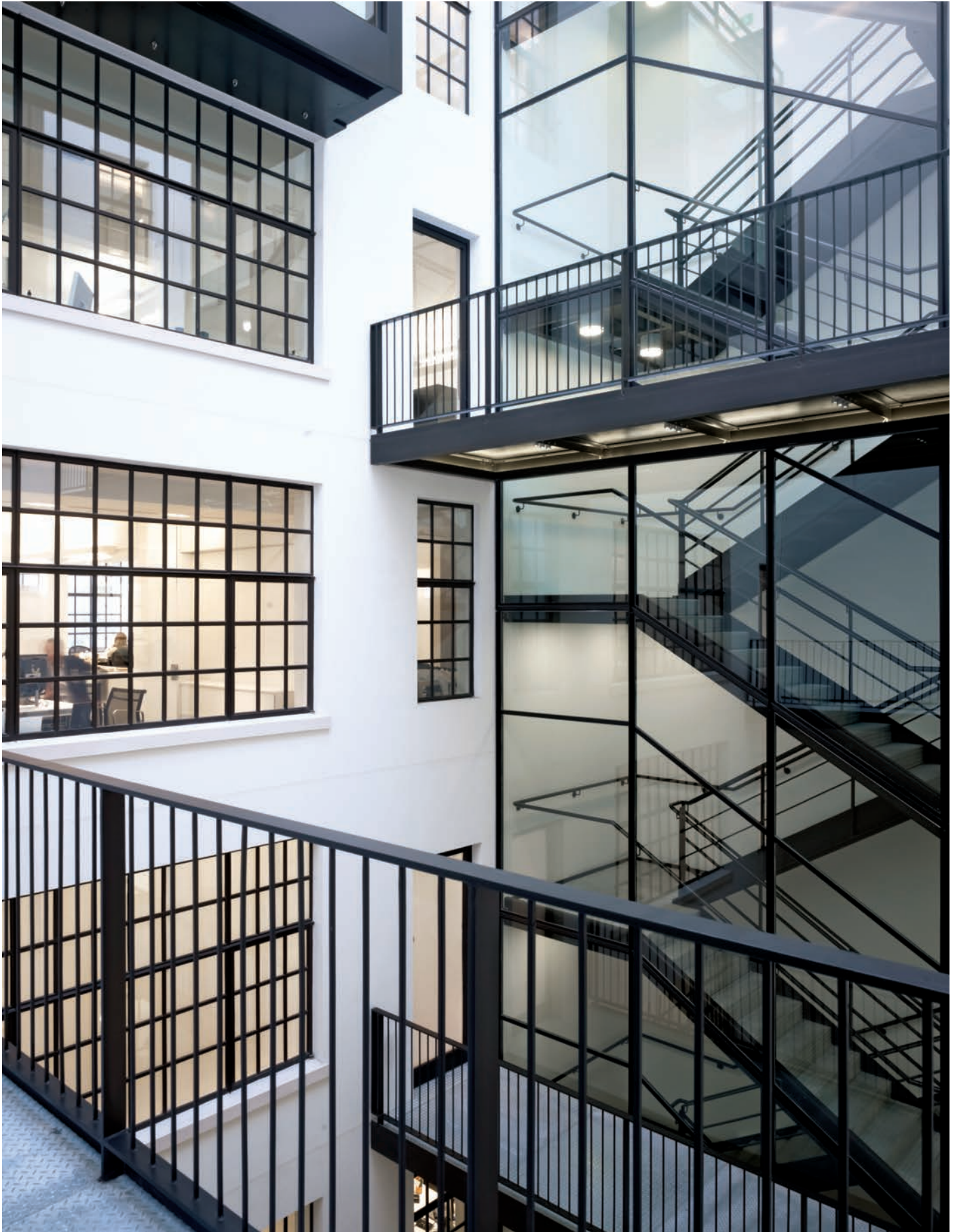

View from a typical bridge in the lightwell



View from inside a seventh floor atrium pop out

A645_449 © Timothy Soar



View from the escape stairs of the lightwell bridges and seventh floor atrium pop outs



View of the lightwell and the glazed roof to the ground and lower ground office

A645_451 © Timothy Soar

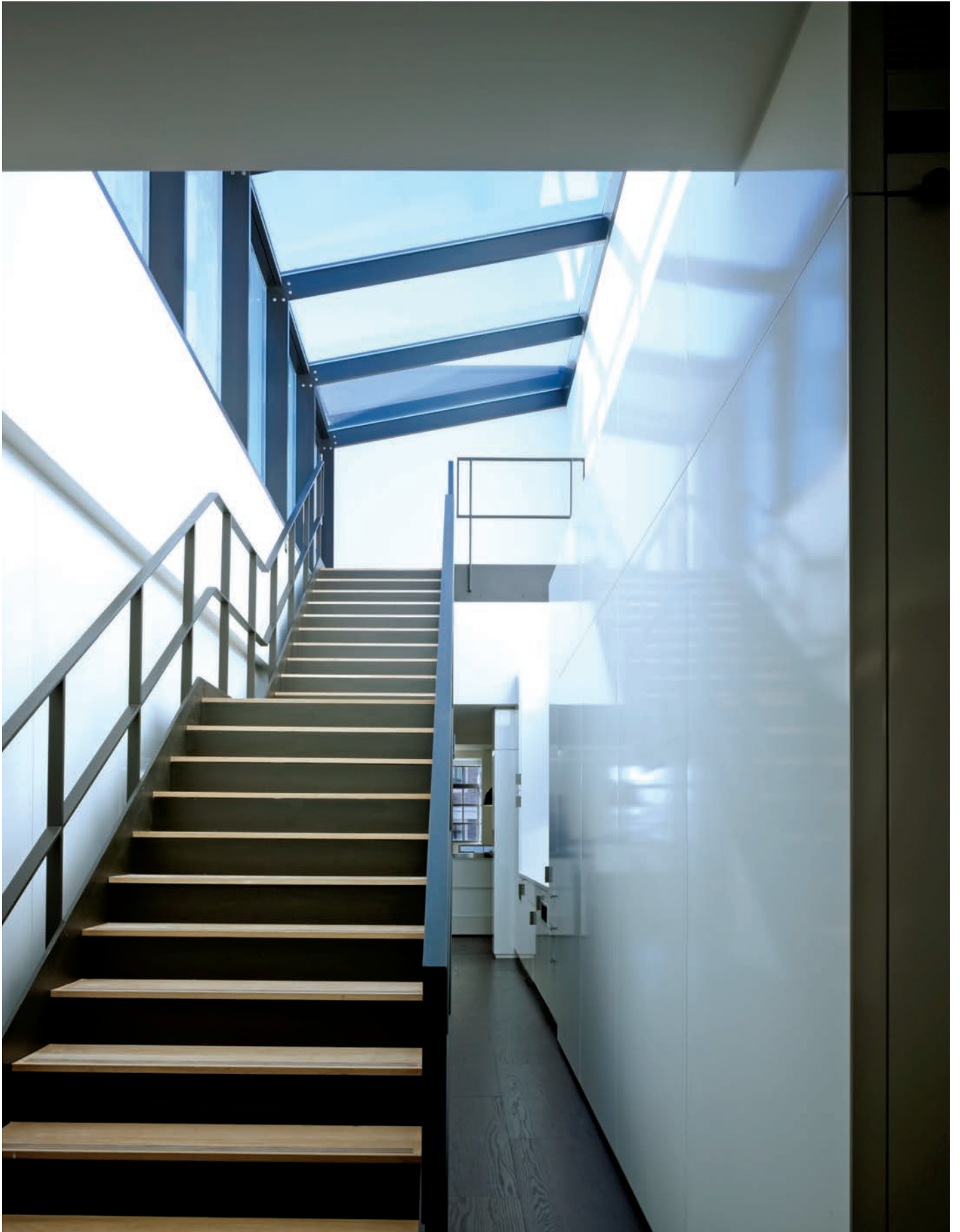

View up the stairs of the seventh floor pop up to the south roof terrace

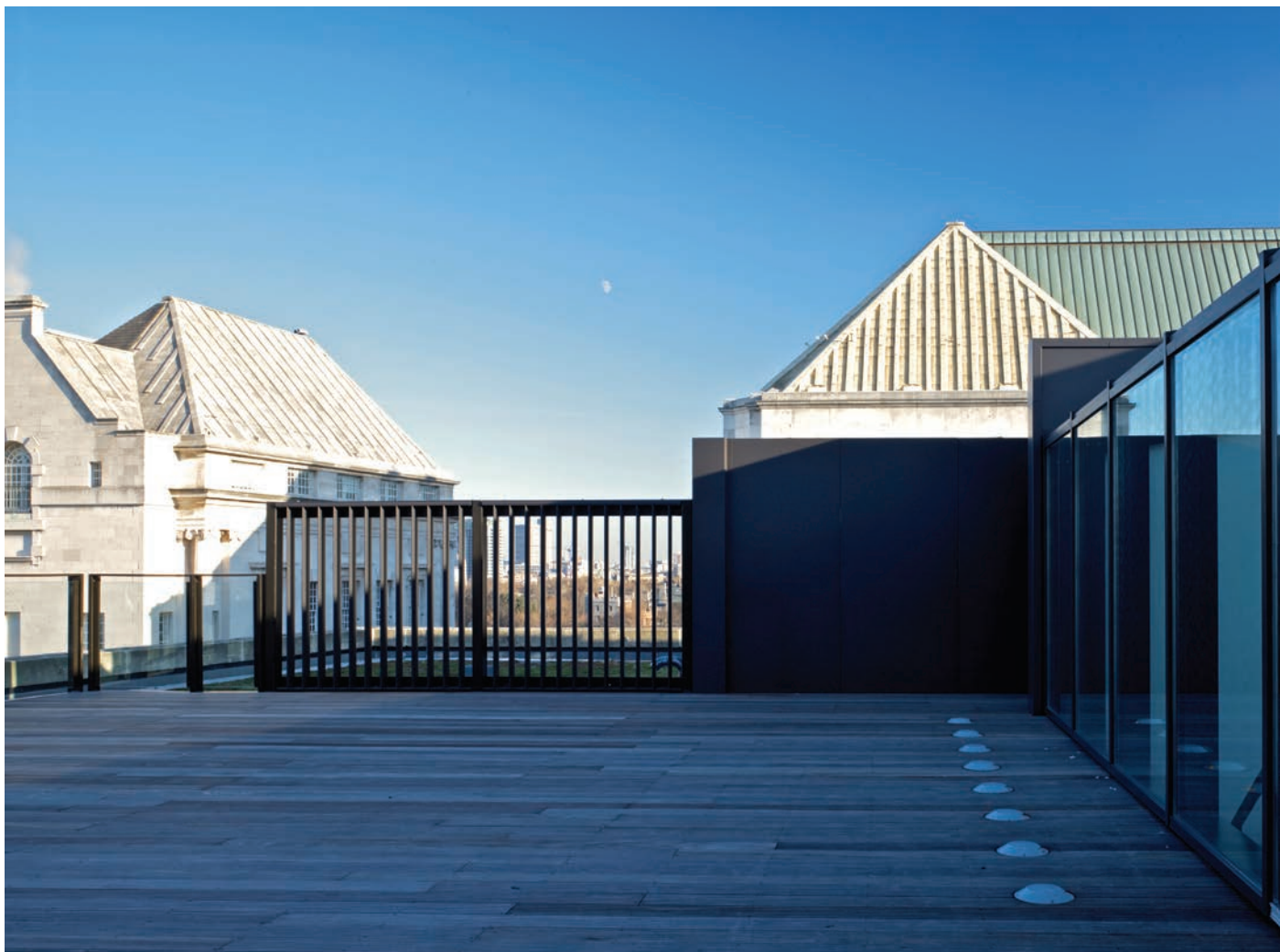

View from the north terrace towards Thames House and the city beyond

A645_445 © Timothy Soar



View from the roof terrace past thames House; M15 towards the Thames River, London



View of the south roof terrace looking west

A645_447 © Timothy Soar